

---

**S P E C F I L E**

---

**Product Number :** PT-**RX110B/RX110W**  
PT-**RX110LB/RX110LW**

**Product Name :** DLP™ Projectors

**Specifications**

**Main unit**

Power supply		AC100 - 240V 10.4-5.0A 50Hz/60Hz
Power consumption		1,050W
		NORMAL: 742W ECO: 617W LONG LIFE1: 410-588
		LONG LIFE 2: 375-588W LONG LIFE 3: 349-588W SHUTTER: 82W
		STANDBY MODE [ECO]*1: 0.2W STANDBY MODE [NORMAL]: 3W
		STANDBY MODE (When the [QUICK STARTUP] function is enabled): Approx. 85 W
		*Operating Temperature: 25 °C (77 °F), Altitude: 700m (2,297 ft),
		IEC62087: 2008 Broadcast contents,
		Picture mode: Standard, Dynamic Contrast2
BTU value		Max 3,584 BTU
DLP™ chip	Panel size	17.8 mm (0.7 in) diagonal (4:3 aspect ratio)
	Display method	DLP™ chip × 1, DLP™ system
	Pixels	786,432 (1024 × 768) × 1, total of 786,432 pixels
Lens	PT-RX110B/W	Powered zoom/focus lenses (1.8–2.5:1), F 1.7–1.9, f 25.6–35.7 mm
	PT-RX110LB/LW	Optional powered zoom/focus lenses and fixed-focus lens
Light source		Laser Diode Laser class 1(Class3R for US models)
Illumination life of set		Varies depending on operation mode setting.
		20,000 hours at half luminance (NORMAL/QUIET1/QUIET2)/
		24,000 hours at half luminance (ECO)
		* Temperature: 30°C (86°F), Altitude 700m (2,297 ft),Dynamic Contrast3
		Under conditions of 0.15 mg/m3 of particulate matter
		Lumen maintenance rate(rough estimate) : 5000 hours 80% / 10000 hours 70%
		43,800 hours at constant luminance (LONG LIFE1)
		61,320 hours at constant luminance (LONG LIFE2)
		87,600 hours at constant luminance (LONG LIFE3)
Screen size		1.27–15.24 m (50–600 inches) (4:3 aspect ratio)
		*1.27 – 5.08 m (50 – 200 inches) with the ET-DLE055 (4:3 aspect ratio)
		*2.54 – 7.62 m (100 – 350 inches) with the ET-DLE030 (4:3 aspect ratio)
Brightness*3		Varies depending on operation mode setting.
		10,000 lumens*3/10,400 lumens (Center)*2
		10,000 lumens (Half luminance) (NORMAL)
		8,000 lumens (Half luminance) (ECO)
		8,500 lumens (Half luminance) (QUIET1)
		6,400 lumens (Half luminance) (QUIET2)
		3,900 lumens (Constant luminance) (LONG LIFE1)
		3,300 lumens (Constant luminance) (LONG LIFE2)
		2,700 lumens (Constant luminance) (LONG LIFE3)
Center-to-corner uniformity*3		90%
Contrast*3		10,000:1 (All White/All Black) (Dynamic Contrast3)
Resolution		1024 × 768 pixels (Input signals that exceed this resolution will be converted to 1024 × 768 pixels.)
Scanning frequency	HDMI/DVI-D	fH: 15- 100kHz, fV: 24 - 120Hz, dot clock: 25 - 162 MHz
		525i (480i)*4, 625i (576i)*4, 525p (480p), 625p (576p), 750 (720)/60p,
		750 (720)/50p, 1125 (1080)/60i, 1125 (1080)/50i, 1125 (1080)/25p,
		1125 (1080)/24p, 1125 (1080)/24sF, 1125 (1080)/30p, 1125 (1080)/60p,
		1125 (1080)/50p, VGA (640 x 480) - WUXGA (1920 x 1200) compatible
		with non-interlaced signals only
	RGB	fH: 15- 100kHz, fV: 24 - 120Hz, dot clock: 20 - 162 MHz

Scanning frequency	YPbPr (YCbCr)	525i (480i):	fH 15.73 kHz; fV 59.9 Hz,
		625i (576i):	fH 15.63 kHz; fV 59.9 Hz,
		525p (480p):	fH 31.50 kHz; fV 60 Hz,
		625p (576p):	fH 31.25 kHz; fV 50 Hz,
		750 (720)/60p:	fH 45.00 kHz; fV 60 Hz,
		750 (720)/50p:	fH 37.50 kHz; fV 50 Hz,
		1125 (1080)/60i:	fH 33.75 kHz; fV 60 Hz,
		1125 (1080)/50i:	fH 28.13 kHz; fV 50 Hz,
		1125 (1080)/25p:	fH 28.13 kHz; fV 25 Hz,
		1125 (1080)/24p:	fH 27.00 kHz; fV 24 Hz,
		1125 (1080)/24sF:	fH 27.00 kHz; fV 48 Hz,
		1125 (1080)/30p:	fH 33.75 kHz; fV 30 Hz,
		1125 (1080)/60p:	fH 67.50 kHz; fV 60 Hz,
Video/S-Video		fH: 15.73 kHz, fV: 59.9 Hz [NTSC/NTSC4.43/PAL-M/PAL60]	
		fH: 15.63 kHz, fV: 50 Hz [PAL/PAL-N/SECAM]	

Geometry correction range

Projection lens Model No.	Only [KEYSTONE] used		[KEYSTONE] and [CURVED] used together				Only [CURVED] used	
	Vertical keystone correction angle $\alpha$ (°)	Horizontal keystone correction angle $\beta$ (°)	Vertical keystone correction angle $\alpha$ (°)	Horizontal keystone correction angle $\beta$ (°)	Min. value of R2/L2	Min. value of R3/L3	Min. value of R2/L2	Min. value of R3/L3
Supplied lens/ET-DLE170	±40	±15	±20	±15	0.9	1.7	0.5	1
ET-DLE030*	+5/-0	0	—	—	—	—	—	—
ET-DLE055	±22	±15	±8	±8	1.7	4.3	1	2.6
ET-DLE085	±22	±15	±8	±8	1.7	4.3	1	2.6
ET-DLE105	±22	±15	±8	±8	1.7	4.3	1	2.6
ET-DLE150	±40	±15	±20	±15	1.1	2.6	0.6	1.5
ET-DLE250	±40	±15	±20	±15	0.7	1.3	0.4	0.7
ET-DLE350	±40	±15	±20	±15	0.4	0.8	0.3	0.5
ET-DLE450	±40	±15	±20	±15	0.3	0.6	0.2	0.3

\* Only the vertical keystone correction angle can be corrected in the direction in which the projector body moves away from the screen.

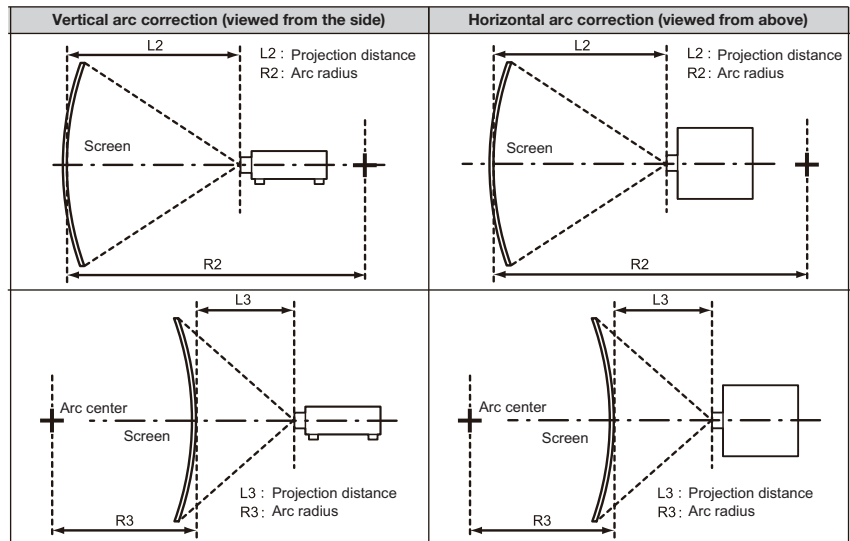
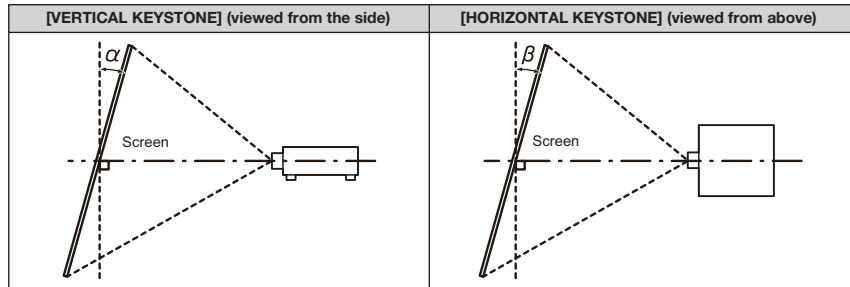

- When [GEOMETRY] is used, the focus of the entire screen may be lost as correction increases.
- Make the curved screen a circular arc shape with one part of a perfect circle removed.
- Adjustment range of the [GEOMETRY] items may not match the listed projection range depending on the projection lens. Use this projector within the projection range, otherwise the correction may not work.

Optical axis shift		Vertical: +45%, -13%(powered), Horizontal: +30%, -10% (When using the ET-DLE085/DLE105, +28%, -10%) (powered) <b>NOTE: Optical axis shift function cannot be operated when used with the ET-DLE055. If using the ET-DLE030, the optical axis is fixed.</b>
Installation		Ceiling/floor, front/rear, 360 degree free installation
Terminals	HDMI IN DVI-D IN  RGB 1 IN R, G, B  Y, PB, PR (Y, CB, CR) Y,C Video RGB 2 IN R, G, B  Y, PB, PR(Y, CB, CR) SERIAL/MULTI PROJECTOR SYNC IN SERIAL/MULTI PROJECTOR SYNC OUT REMOTE 1 IN REMOTE 1 OUT REMOTE 2 IN LAN/DIGITAL LINK	HDMI 19-pin × 1, Deep Color, compatible with HDCP, DVI-D 24-pin × 1, DVI 1.0 compliant, compatible with HDCP, for single link only BNC × 5 R: 0.7 Vp-p, 75 ohms, G: 0.7 Vp-p (G: 1.0 Vp-p for sync on G), 75 ohms, B: 0.7 Vp-p, 75 ohms HD, VD/SYNC: TTL, high impedance, positive/negative automatic Y: 1.0 Vp-p (including sync signal), PB/PR (CB/CR): 0.7 Vp-p, 75 ohms Y: 1.0Vp-p, C: 0.286Vp-p, 75 ohms 1.0Vp-p, 75 ohms D-sub HD 15-pin (female) × 1 R: 0.7 Vp-p, 75 ohms, G: 0.7 Vp-p (G: 1.0 Vp-p for sync on G), 75 ohms, B: 0.7 Vp-p, 75 ohms HD, VD/SYNC: TTL, high impedance, positive/negative automatic Y: 1.0 Vp-p (including sync signal), PB/PR(CB/CR): 0.7 Vp-p, 75 ohms D-sub 9-pin (female) × 1 for external control (RS-232C compliant) D-sub 9-pin (male) x 1 for link control M3 jack x 1 for wired remote control M3 jack x 1 for link control (for wired remote control) D-sub 9-pin (female) x1 for external control (parallel) RJ-45 x 1 for network and DIGITAL LINK (video/network/serial control) connection, 100Base-TX, compliant with PJLink™(Class 1) Deep Color, HDCP
Power cord length		3.0 m (9 ft 10 in)
Cabinet materials		Molded plastic
Dimensions (W × H × D)	PT-RX110B/RX110W  PT-RX110LB/RX110LW	498 x 200*5 x 581mm (19-19/32 x 7-7/8*5 x 22-7/8in ) with supplied lens 498 x 200*5 x 538 mm (19-19/32 x 7-7/8*5 x 21-3/16in) without lens
Weight	PT-RX110B/RX110W PT-RX110LB/RX110LW	Approx. 23.2kg (51.1lbs) with supplied lens Approx. 22.4kg (49.4lbs) without lens
Operation noise		41dB (37dB[QUIET1] / 35dB[QUIET2])
Operating temperature		0–45 °C (32–113 °F)*6
Operating humidity		10%–80% (no condensation)

**Remote control unit**

Power supply	3 V DC (R03/AAA type battery × 2)
Operation range	Approx. 30 m (98 ft 5 in) when operated from directly in front of the signal receptor
Dimensions (W × H × D)	48 × 145 × 27 mm (1-57/64 × 5-45/64 × 1-3/64 in)
Weight*7	Approx. 102 g (3.6 oz) including batteries

**Supplied accessories**

Power cord with secure lock (× 1) (× 2 for EU models)
Wireless/wired remote control unit (× 1)
Batteries for remote control (R03/AAA type × 2)
Software CD-ROM (Logo Transfer Software, Multi Monitoring & Control Software) (× 1)
Lens Mount Cover (× 1)
Lens cover (× 1) (Only models with lens)

**Optional accessories**

Digital interface box	ET-YFB100G
Digital LINK Switcher	ET-YFB200G
Zoom lens (0.8–1.0:1)	ET-DLE085
Zoom lens (1.0–1.4:1)	ET-DLE105
Zoom lens (1.3–2.0:1)	ET-DLE150
Zoom lens (1.8–2.5:1)	ET-DLE170 (same as supplied lens)
Zoom lens (2.4–3.7:1)	ET-DLE250
Zoom lens (3.7–5.6:1)	ET-DLE350
Zoom lens (5.5–8.9:1)	ET-DLE450
Fixed-focus lens (0.38:1)	ET-DLE030
Fixed-focus lens (0.8:1)	ET-DLE055
Ceiling mount bracket	ET-PKD120H (for high ceilings) ET-PKD120S (for low ceilings)
High-ceiling mount bracket (6-axis adjustment mechanism)	ET-PKD130H
Attachment for ceiling mount bracket	ET-PKD130B
Geometry Manager Pro Upgrade kit	ET-UK20
Auto Screen Adjustment Upgrade kit	ET-CUK10
Early Warning Software	ET-SWA100*

\* The symbol at the end of the part number will vary depending on the type of license.

- \*1 When the **STANDBY MODE** is set to **Eco**, network functions such as power on over the LAN will not operate.
- \*2 The value of the light output at the center region of the projected image is extracted based on the light output measurement method defined by the ISO/IEC 21118:2012 international standards.
- \*3 Measurement, measuring conditions, and method of notation all comply with ISO 21118 international standards.
- \*4 Only compatible with dot clock frequency of 27 MHz (pixel repetition signal).
- \*5 with legs at shortest position.
- \*6 Limits the luminance when used in locations from 0m to 2,700m (0ft to 8,858ft) above sea level at ambient temperatures of 35°C (95°F) or higher, or from 2,700m to 4,200m (8,858ft to 13,780ft) above sea level at ambient temperatures of 25°C (77°F) or higher.
- \*7 Average value. May differ depending on models.

Dimensions

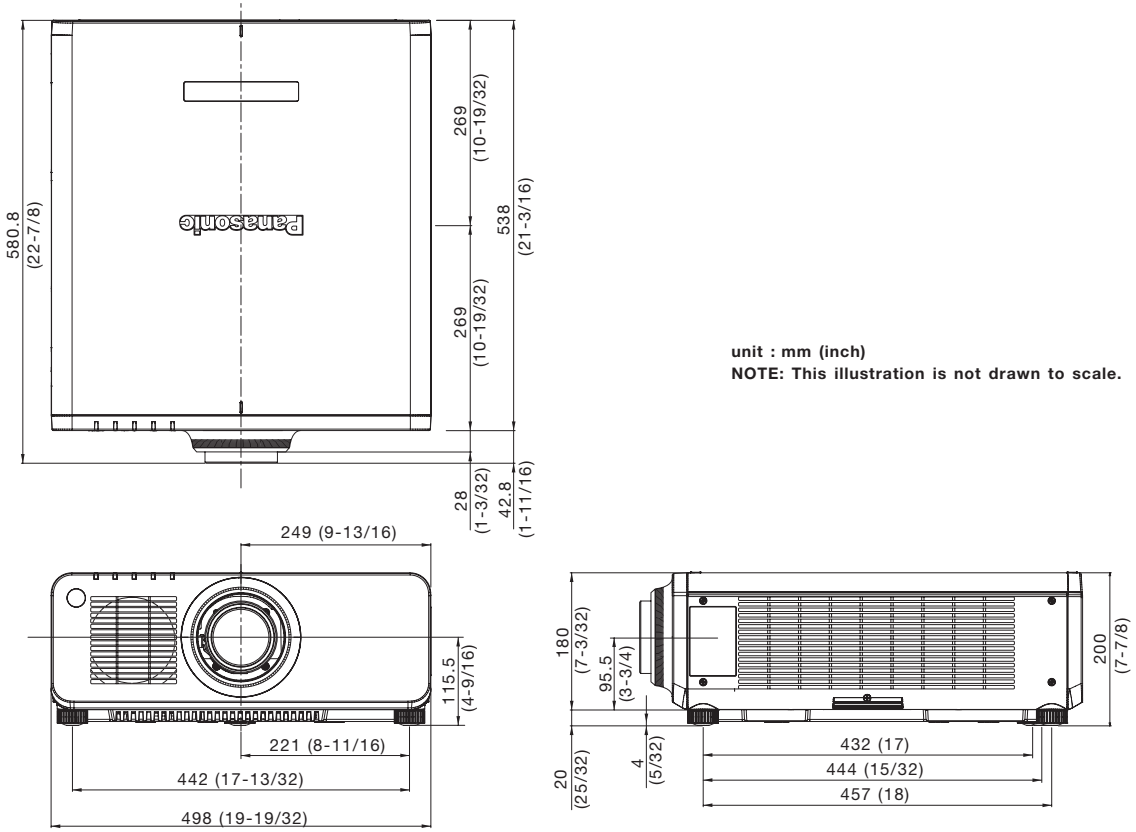

Terminals

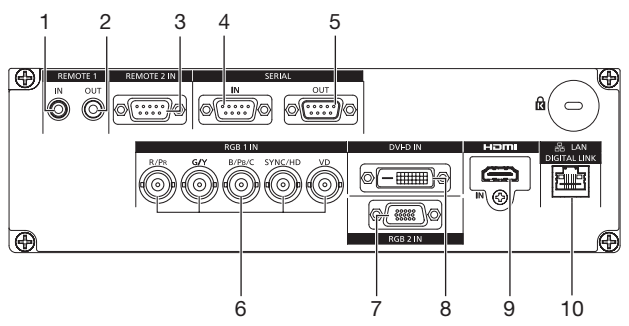

- 1 REMOTE 1 INPUT
- 2 REMOTE 1 OUTPUT
- 3 REMOTE 2 INPUT
- 4 SERIAL/MULTI PROJECTOR SYNC INPUT
- 5 SERIAL/MULTI PROJECTOR SYNC OUTPUT
- 6 RGB 1 INPUT
- 7 RGB 2 INPUT
- 8 DVI-D INPUT
- 9 HDMI INPUT
- 10 LAN/DIGITAL LINK TERMINAL

Standard setting-up position (If using other than the ET-DLE030)

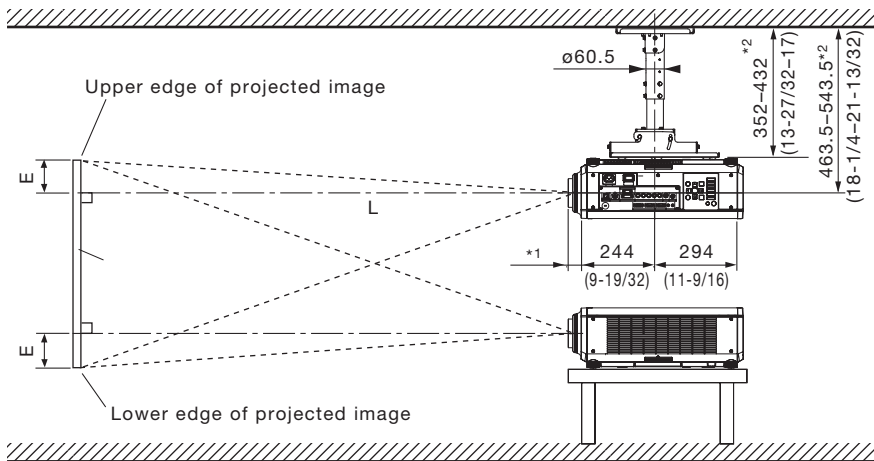

\*1 When the lens protrudes to the maximum.  
 84 mm (3-5/16 in) with the ET-DLE085  
 88 mm (3-15/32 in) with the ET-DLE105  
 44 mm (1-23/32 in) with the ET-DLE150  
 43 mm (1-11/16 in)  
 with the supplied lens/ET-DLE170  
 45 mm (1-25/32 in) with the ET-DLE250  
 51 mm (2 in) with the ET-DLE350  
 95 mm (3-3/4 in) with the ET-DLE450  
 27 mm (1-1/16 in) with the ET-DLE055

\*2 Adjustable in 40 mm (1-9/16 in) steps.

unit : mm (inch)

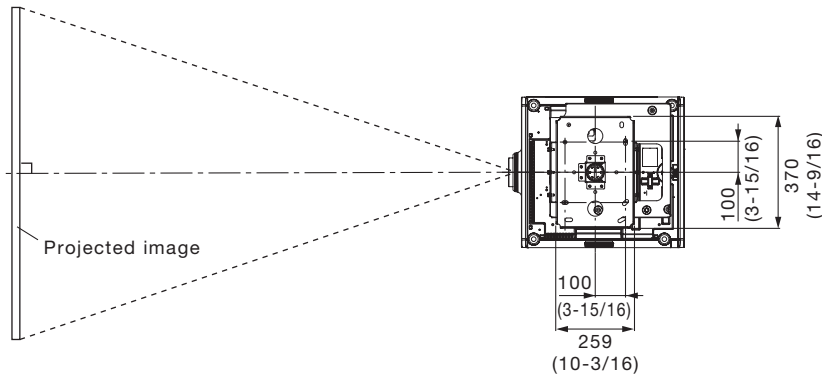

NOTE:

Illustrations show the projector installed using optional ceiling mount bracket ET-PKD120H, optional bracket assembly ET-PKD130B and an optional lens.

This illustration is not drawn to scale.

Caution:

- All construction work should be done by a qualified technician.
- When mounting to the ceiling, use the special mounting bracket. Furthermore, in order to prevent it from falling down from the ceiling, use the supplied wire on the mounting bracket.

Projection distance for 4:3 aspect ratio screen (If using other than the ET-DLE030)

**Unit: meters**

Screen size (diagonal)		Distance to screen (L)														Height from the edge of screen to center of lens (H)			
		Zoom lens														Fixed-focus lens	Zoom lens		Fixed-focus lens
		ET-DLE085	ET-DLE105	ET-DLE150	Supplied lens/ ET-DLE170		ET-DLE250	ET-DLE350	ET-DLE450	ET-DLE055	Supplied lens/ ET-DLE150/ 250/350/450		ET-DLE085/ 105	ET-DLE055					
[m]	[in]	min.	max.	min.	max.	min.	max.	min.	max.		min.	max.	min.		max.	min.	max.	min.	max.
1.27/ 50	0.81	1.01	1.01	1.38	1.34	1.97	<b>1.78</b>	<b>2.51</b>	2.36	3.78	3.71	5.68	5.52	8.91	0.81	0 – 0.48	0.04 – 0.48	0.38	
1.52/ 60	0.98	1.22	1.22	1.66	1.62	2.37	<b>2.15</b>	<b>3.03</b>	2.85	4.55	4.48	6.84	6.69	10.75	0.98	0 – 0.58	0.05 – 0.58	0.46	
1.78/ 70	1.15	1.43	1.43	1.94	1.90	2.77	<b>2.52</b>	<b>3.55</b>	3.34	5.32	5.25	8.01	7.86	12.60	1.15	0 – 0.67	0.05 – 0.67	0.53	
2.03/ 80	1.32	1.64	1.65	2.23	2.18	3.18	<b>2.89</b>	<b>4.06</b>	3.83	6.09	6.02	9.17	9.02	14.44	1.32	0 – 0.77	0.06 – 0.77	0.61	
2.29/ 90	1.49	1.85	1.86	2.51	2.46	3.58	<b>3.26</b>	<b>4.58</b>	4.31	6.86	6.79	10.33	10.19	16.28	1.49	0 – 0.86	0.07 – 0.86	0.69	
2.54/100	1.66	2.07	2.07	2.80	2.74	3.98	<b>3.63</b>	<b>5.10</b>	4.80	7.63	7.56	11.50	11.35	18.12	1.66	0 – 0.96	0.08 – 0.96	0.76	
3.05/120	2.00	2.49	2.49	3.37	3.30	4.79	<b>4.37</b>	<b>6.13</b>	5.78	9.17	9.10	13.82	13.68	21.81	2.01	0 – 1.15	0.09 – 1.15	0.91	
3.81/150	2.51	3.12	3.13	4.22	4.14	6.00	<b>5.48</b>	<b>7.68</b>	7.24	11.49	11.41	17.31	17.18	27.33	2.52	0 – 1.44	0.11 – 1.44	1.14	
5.08/200	3.36	4.18	4.19	5.64	5.54	8.02	<b>7.33</b>	<b>10.26</b>	9.69	15.34	15.26	23.13	23.00	36.54	3.38	0 – 1.92	0.15 – 1.92	1.52	
6.35/250	4.21	5.23	5.25	7.06	6.94	10.03	<b>9.18</b>	<b>12.85</b>	12.13	19.20	19.11	28.94	28.83	45.75	–	0 – 2.40	0.19 – 2.40	–	
7.62/300	5.07	6.29	6.31	8.49	8.33	12.05	<b>11.03</b>	<b>15.43</b>	14.57	23.06	22.96	34.76	34.66	54.97	–	0 – 2.88	0.23 – 2.88	–	
8.89/350	5.92	7.34	7.37	9.91	9.73	14.07	<b>12.88</b>	<b>18.02</b>	17.01	26.91	26.81	40.57	40.48	64.18	–	0 – 3.36	0.27 – 3.36	–	
10.16/400	6.77	8.40	8.43	11.33	11.13	16.08	<b>14.73</b>	<b>20.60</b>	19.45	30.77	30.65	46.39	46.31	73.39	–	0 – 3.84	0.30 – 3.84	–	
12.70/500	8.48	10.51	10.56	14.18	13.92	20.12	<b>18.43</b>	<b>25.77</b>	24.33	38.48	38.35	58.02	57.96	91.81	–	0 – 4.80	0.38 – 4.80	–	
15.24 600	10.18	12.62	12.68	17.02	16.72	24.15	<b>22.13</b>	<b>30.94</b>	29.22	46.19	46.05	69.65	69.61	110.23	–	0 – 5.76	0.46 – 5.76	–	

**Unit: feet**

Screen size (diagonal)		Distance to screen (L)														Height from the edge of screen to center of lens (H)			
		Zoom lens														Fixed-focus lens	Zoom lens		Fixed-focus lens
		ET-DLE085	ET-DLE105	ET-DLE150	Supplied lens/ ET-DLE170		ET-DLE250	ET-DLE350	ET-DLE450	ET-DLE055	Supplied lens/ ET-DLE150/ 250/350/450		ET-DLE085/ 105	ET-DLE055					
[m]	[in]	min.	max.	min.	max.	min.	max.	min.	max.		min.	max.	min.		max.	min.	max.	min.	max.
1.27/ 50	2.6	3.3	3.3	4.5	4.4	6.5	<b>5.8</b>	<b>8.2</b>	7.7	12.4	12.2	18.6	18.1	29.2	2.7	0 – 1.6	0.1 – 1.6	1.3	
1.52/ 60	3.2	4.0	4.0	5.4	5.3	7.8	<b>7.0</b>	<b>9.9</b>	9.4	14.9	14.7	22.5	21.9	35.3	3.2	0 – 1.9	0.2 – 1.9	1.5	
1.78/ 70	3.8	4.7	4.7	6.4	6.2	9.1	<b>8.3</b>	<b>11.6</b>	11.0	17.5	17.2	26.3	25.8	41.3	3.8	0 – 2.2	0.2 – 2.2	1.7	
2.03/ 80	4.3	5.4	5.4	7.3	7.2	10.4	<b>9.5</b>	<b>13.3</b>	12.6	20.0	19.8	30.1	29.6	47.4	4.3	0 – 2.5	0.2 – 2.5	2.0	
2.29/ 90	4.9	6.1	6.1	8.2	8.1	11.7	<b>10.7</b>	<b>15.0</b>	14.2	22.5	22.3	33.9	33.4	53.4	4.9	0 – 2.8	0.2 – 2.8	2.3	
2.54/100	5.4	6.8	6.8	9.2	9.0	13.1	<b>11.9</b>	<b>16.7</b>	15.8	25.0	24.8	37.7	37.2	59.5	5.5	0 – 3.1	0.2 – 3.1	2.5	
3.05/120	6.6	8.2	8.2	11.1	10.8	15.7	<b>14.3</b>	<b>20.1</b>	19.0	30.1	29.9	45.4	44.9	71.5	6.6	0 – 3.8	0.3 – 3.8	3.0	
3.81/150	8.2	10.2	10.3	13.8	13.6	19.7	<b>18.0</b>	<b>25.2</b>	23.8	37.7	37.4	56.8	56.4	89.7	8.3	0 – 4.7	0.4 – 4.7	3.8	
5.08/200	11.0	13.7	13.7	18.5	18.2	26.3	<b>24.0</b>	<b>33.7</b>	31.8	50.3	50.1	75.9	75.5	119.9	11.1	0 – 6.3	0.5 – 6.3	5.0	
6.35/250	13.8	17.2	17.2	23.2	22.8	32.9	<b>30.1</b>	<b>42.2</b>	39.8	63.0	62.7	95.0	94.6	150.1	–	0 – 7.9	0.6 – 7.9	–	
7.62/300	16.6	20.6	20.7	27.9	27.3	39.5	<b>36.2</b>	<b>50.6</b>	47.8	75.6	75.3	114.0	113.7	180.3	–	0 – 9.4	0.8 – 9.4	–	
8.89/350	19.4	24.1	24.2	32.5	31.9	46.1	<b>42.3</b>	<b>59.1</b>	55.8	88.3	87.9	133.1	132.8	210.6	–	0 – 11.0	0.9 – 11.0	–	
10.16/400	22.2	27.5	27.7	37.2	36.5	52.8	<b>48.3</b>	<b>67.6</b>	63.8	100.9	100.6	152.2	151.9	240.8	–	0 – 12.6	1.0 – 12.6	–	
12.70/500	27.8	34.5	34.6	46.5	45.7	66.0	<b>60.5</b>	<b>84.5</b>	79.8	126.2	125.8	190.4	190.2	301.2	–	0 – 15.8	1.3 – 15.8	–	
15.24 600	33.4	41.4	41.6	55.8	54.9	79.2	<b>72.6</b>	<b>101.5</b>	95.9	151.5	151.1	228.5	228.4	361.7	–	0 – 18.9	1.5 – 18.9	–	

- The value for L (distance to screen) varies slightly within ±5% depending on the zoom lens characteristics.
- The zoom lens characteristics may cause slight image distortion.
- When vertical keystone correction is used, the image is corrected in the direction that reduces its projected size.
- The brightness varies depending on the zoom setting.

Note: When the ET-DLE055 is mounted, the optical lens shift function cannot be used.



Projection distance for 16:9 aspect ratio screen (If using other than the ET-DLE030)

Unit: meters

Screen size (diagonal)		Distance to screen (L)														Height from the edge of screen to center of lens (H)				
		Zoom lens														Fixed-focus lens	Zoom lens		Fixed-focus lens	
		ET-DLE085	ET-DLE105	ET-DLE150	Supplied lens/ ET-DLE170		ET-DLE250	ET-DLE350	ET-DLE450	ET-DLE055	Supplied lens/ ET-DLE150/ 250/350/450	ET-DLE085/ 105	ET-DLE055							
[m]	[in]	min.	max.	min.	max.	min.	max.	min.	max.	min.	max.	min.	max.	min.	max.		min.	max.		
1.27/ 50	0.88	1.11	1.10	1.50	1.47	2.15	<b>1.94</b>	<b>2.74</b>	2.58	4.12	4.06	6.20	6.05	9.74	0.88	-0.21	-0.52	-0.16	-0.52	0.31
1.52/ 60	1.07	1.34	1.34	1.81	1.77	2.59	<b>2.34</b>	<b>3.31</b>	3.11	4.96	4.90	7.47	7.32	11.74	1.07	-0.25	-0.63	-0.19	-0.63	0.37
1.78/ 70	1.25	1.57	1.57	2.12	2.08	3.03	<b>2.75</b>	<b>3.87</b>	3.64	5.80	5.73	8.74	8.58	13.75	1.26	-0.29	-0.73	-0.23	-0.73	0.44
2.03/ 80	1.44	1.79	1.80	2.43	2.38	3.47	<b>3.15</b>	<b>4.43</b>	4.18	6.64	6.57	10.00	9.85	15.76	1.44	-0.33	-0.84	-0.26	-0.84	0.50
2.29/ 90	1.62	2.02	2.03	2.74	2.69	3.91	<b>3.55</b>	<b>4.99</b>	4.71	7.48	7.41	11.27	11.12	17.76	1.63	-0.37	-0.94	-0.29	-0.94	0.56
2.54/100	1.81	2.25	2.26	3.05	2.99	4.34	<b>3.96</b>	<b>5.56</b>	5.24	8.32	8.25	12.54	12.39	19.77	1.82	-0.41	-1.05	-0.32	-1.05	0.62
3.05/120	2.18	2.71	2.72	3.67	3.60	5.22	<b>4.76</b>	<b>6.68</b>	6.30	10.00	9.93	15.07	14.93	23.78	2.19	-0.49	-1.26	-0.39	-1.26	0.75
3.81/150	2.74	3.40	3.42	4.60	4.51	6.54	<b>5.97</b>	<b>8.37</b>	7.90	12.52	12.44	18.87	18.74	29.81	2.75	-0.62	-1.57	-0.49	-1.57	0.93
5.08/200	3.67	4.55	4.57	6.15	6.04	8.74	<b>7.99</b>	<b>11.19</b>	10.56	16.72	16.64	25.21	25.09	39.84	3.68	-0.82	-2.09	-0.65	-2.09	1.25
6.35/250	4.60	5.70	5.73	7.70	7.56	10.94	<b>10.01</b>	<b>14.00</b>	13.22	20.93	20.83	31.54	31.44	49.88	-	-1.03	-2.62	-0.81	-2.62	-
7.62/300	5.52	6.85	6.88	9.25	9.08	13.13	<b>12.02</b>	<b>16.82</b>	15.88	25.13	25.02	37.88	37.78	59.91	-	-1.23	-3.14	-0.97	-3.14	-
8.89/350	6.45	8.00	8.04	10.80	10.61	15.33	<b>14.04</b>	<b>19.63</b>	18.54	29.33	29.22	44.22	44.13	69.95	-	-1.44	-3.66	-1.13	-3.66	-
10.16/400	7.38	9.15	9.19	12.35	12.13	17.53	<b>16.05</b>	<b>22.45</b>	21.20	33.53	33.41	50.55	50.48	79.98	-	-1.64	-4.18	-1.30	-4.18	-
12.70/500	9.24	11.45	11.50	15.45	15.17	21.92	<b>20.09</b>	<b>28.08</b>	26.52	41.93	41.79	63.22	63.17	100.05	-	-2.05	-5.23	-1.62	-5.23	-
15.24 600	11.10	13.75	13.82	18.55	18.22	26.31	<b>24.12</b>	<b>33.71</b>	31.84	50.33	50.18	75.89	75.87	120.12	-	-2.47	-6.28	-1.94	-6.28	-

Unit: feet

Screen size (diagonal)		Distance to screen (L)														Height from the edge of screen to center of lens (H)				
		Zoom lens														Fixed-focus lens	Zoom lens		Fixed-focus lens	
		ET-DLE085	ET-DLE105	ET-DLE150	Supplied lens/ ET-DLE170		ET-DLE250	ET-DLE350	ET-DLE450	ET-DLE055	Supplied lens/ ET-DLE150/ 250/350/450	ET-DLE085/ 105	ET-DLE055							
[m]	[in]	min.	max.	min.	max.	min.	max.	min.	max.	min.	max.	min.	max.	min.	max.		min.	max.		
1.27/ 50	2.9	3.6	3.6	4.9	4.8	7.0	<b>6.4</b>	<b>9.0</b>	8.5	13.5	13.3	20.3	19.8	31.9	2.9	-0.7	-1.7	-0.5	-1.7	1.0
1.52/ 60	3.5	4.4	4.4	5.9	5.8	8.5	<b>7.7</b>	<b>10.8</b>	10.2	16.3	16.1	24.5	24.0	38.5	3.5	-0.8	-2.1	-0.6	-2.1	1.2
1.78/ 70	4.1	5.1	5.2	7.0	6.8	9.9	<b>9.0</b>	<b>12.7</b>	12.0	19.0	18.8	28.7	28.1	45.1	4.1	-0.9	-2.4	-0.7	-2.4	1.4
2.03/ 80	4.7	5.9	5.9	8.0	7.8	11.4	<b>10.3</b>	<b>14.5</b>	13.7	21.8	21.6	32.8	32.3	51.7	4.7	-1.1	-2.7	-0.8	-2.7	1.6
2.29/ 90	5.3	6.6	6.6	9.0	8.8	12.8	<b>11.7</b>	<b>16.4</b>	15.4	24.5	24.3	37.0	36.5	58.3	5.3	-1.2	-3.1	-1.0	-3.1	1.8
2.54/100	5.9	7.4	7.4	10.0	9.8	14.3	<b>13.0</b>	<b>18.2</b>	17.2	27.3	27.1	41.1	40.7	64.9	6.0	-1.3	-3.4	-1.1	-3.4	2.0
3.05/120	7.2	8.9	8.9	12.0	11.8	17.1	<b>15.6</b>	<b>21.9</b>	20.7	32.8	32.6	49.4	49.0	78.0	7.2	-1.6	-4.1	-1.3	-4.1	2.5
3.81/150	9.0	11.2	11.2	15.1	14.8	21.5	<b>19.6</b>	<b>27.5</b>	25.9	41.1	40.8	61.9	61.5	97.8	9.0	-2.0	-5.1	-1.6	-5.1	3.1
5.08/200	12.0	14.9	15.0	20.2	19.8	28.7	<b>26.2</b>	<b>36.7</b>	34.6	54.9	54.6	82.7	82.3	130.7	12.1	-2.7	-6.9	-2.1	-6.9	4.1
6.35/250	15.1	18.7	18.8	25.3	24.8	35.9	<b>32.8</b>	<b>45.9</b>	43.4	68.7	68.3	103.5	103.1	163.6	-	-3.4	-8.6	-2.7	-8.6	-
7.62/300	18.1	22.5	22.6	30.3	29.8	43.1	<b>39.4</b>	<b>55.2</b>	52.1	82.4	82.1	124.3	124.0	196.6	-	-4.0	-10.3	-3.2	-10.3	-
8.89/350	21.2	26.3	26.4	35.4	34.8	50.3	<b>46.1</b>	<b>64.4</b>	60.8	96.2	95.8	145.1	144.8	229.5	-	-4.7	-12.0	-3.7	-12.0	-
10.16/400	24.2	30.0	30.2	40.5	39.8	57.5	<b>52.7</b>	<b>73.7</b>	69.5	110.0	109.6	165.8	165.6	262.4	-	-5.4	-13.7	-4.2	-13.7	-
12.70/500	30.3	37.6	37.7	50.7	49.8	71.9	<b>65.9</b>	<b>92.1</b>	87.0	137.6	137.1	207.4	207.3	328.2	-	-6.7	-17.2	-5.3	-17.2	-
15.24 600	36.4	45.1	45.3	60.9	59.8	86.3	<b>79.1</b>	<b>110.6</b>	104.5	165.1	164.6	249.0	248.9	394.1	-	-8.1	-20.6	-6.4	-20.6	-

- The value for L (distance to screen) varies slightly within ±5% depending on the zoom lens characteristics.
- The zoom lens characteristics may cause slight image distortion.
- When vertical keystone correction is used, the image is corrected in the direction that reduces its projected size.
- The brightness varies depending on the zoom setting.

Note: When the ET-DLE055 is mounted, the optical lens shift function cannot be used.

Standard setting-up position (If using the ET-DLE030)

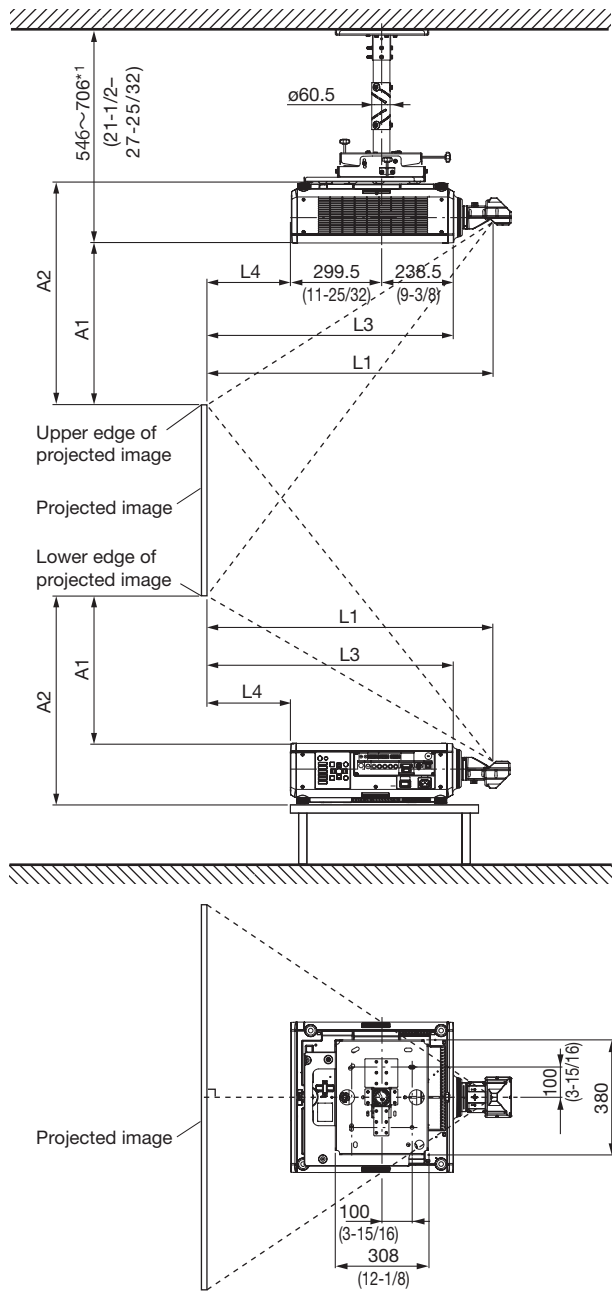

unit : mm (inch)

NOTE:

Illustrations show the projector installed using optional ceiling mount bracket ET-PKD130H, optional bracket assembly ET-PKD130B and an optional lens. This illustration is not drawn to scale.

\*1 Continuous height adjustment possible.

NOTE:

Illustrations show the projector installed using optional ceiling mount bracket ET-PKD130H, optional bracket assembly ET-PKD130B and an optional lens. This illustration is not drawn to scale.

**Caution:**

- All construction work should be done by a qualified technician.
- When mounting to the ceiling, use the special mounting bracket. Furthermore, in order to prevent it from falling down from the ceiling, use the supplied wire on the mounting bracket.

Projection distance for 4:3 aspect ratio screen (If using the ET-DLE030)

Unit : meters

Ultra-short focal length lens ET-DLE030  
Close-up system dimensions

Throw ratio				0.40:1				
Diagonal image size (Inches)	Diagonal image size (m)	Height (SH)	Width (SW)	Projection distance (From mirror reflective surface to screen) (L1)	From front of set to screen (L3)	From rear of set to screen (L4)	From top of set to bottom edge of screen (A1)	From bottom of set to bottom edge of screen (A2)
100	2.54	1.35	2.15	0.80	0.63	0.10	0.41	0.61
120	3.05	1.62	2.59	0.96	0.79	0.26	0.50	0.70
150	3.81	2.02	3.23	1.20	1.03	0.49	0.65	0.85
200	5.08	2.69	4.31	1.60	1.43	0.89	0.88	1.08
250	6.35	3.37	5.39	1.99	1.83	1.29	1.12	1.32
300	7.62	4.04	6.46	2.39	2.23	1.69	1.36	1.56
350	8.89	4.71	7.54	2.79	2.62	2.09	1.60	1.80

Unit : feet

Ultra-short focal length lens ET-DLE030  
Close-up system dimensions

Throw ratio				0.40:1				
Diagonal image size (Inches)	Diagonal image size (m)	Height (SH)	Width (SW)	Projection distance (From mirror reflective surface to screen) (L1)	From front of set to screen (L3)	From rear of set to screen (L4)	From top of set to bottom edge of screen (A1)	From bottom of set to bottom edge of screen (A2)
100	2.54	4.4	7.1	2.6	2.1	0.3	1.3	2.0
120	3.05	5.3	8.5	3.1	2.6	0.8	1.6	2.3
150	3.81	6.6	10.6	3.9	3.4	1.6	2.1	2.8
200	5.08	8.8	14.1	5.2	4.7	2.9	2.9	3.6
250	6.35	11.0	17.7	6.5	6.0	4.2	3.7	4.3
300	7.62	13.3	21.2	7.8	7.3	5.5	4.5	5.1
350	8.89	15.5	24.7	9.2	8.6	6.8	5.3	5.9

- \* The value for L1 may contain an error of within ±5%.
- \* When using vertical keystone correction, the images will be corrected so that they will tend to be smaller than the specified screen size.
- \* This measurement is not the distance between the rear of the projector and the wall, but is instead the distance between the rear of the projector and the screen surface. Leave at least 500 mm of space between the rear of the projector and the wall and any other objects in order to provide adequate ventilation space. If setting up the projector in a closed room, be sure to provide separate air conditioning and ventilation equipment. If there is insufficient ventilation in the room, radiated heat may build up and cause the protection circuit of the projector to operate.

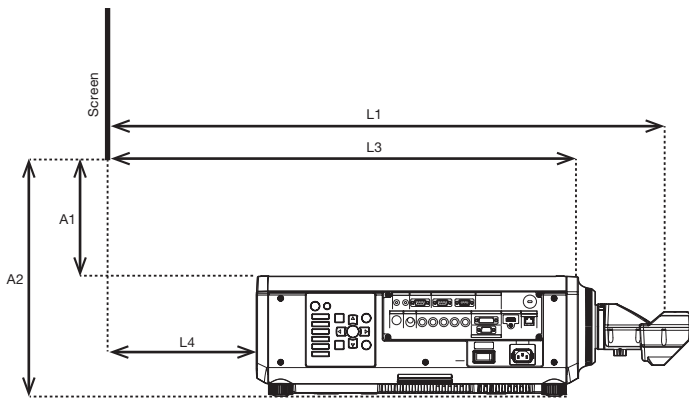

- L1: Projection distance (from screen to mirror reflective surface)
- L3: From screen to front of set
- L4: From screen to rear of set
- A1: From bottom edge of screen to top of set
- A2: From bottom edge of screen to bottom of set

Projection Distance Calculation Table

Screen aspect ratio 4:3

Projection distance calculation formula

$$L1 (m) = 0.3205 \times \text{Diagonal image size} + 0.0047$$

Calculation formula for distance from top of set to bottom edge of screen

$$A1 (m) = 0.1977 \times \text{Diagonal image size} - 0.07210$$

Projection distance for 16:9 aspect ratio screen (If using the ET-DLE030)

Unit : meters

Ultra-short focal length lens ET-DLE030  
Close-up system dimensions

Throw ratio				0.40:1				
Diagonal image size (Inches)	Diagonal image size (m)	Height (SH)	Width (SW)	Projection distance (From mirror reflective surface to screen) (L1)	From front of set to screen (L3)	From rear of set to screen (L4)	From top of set to bottom edge of screen (A1)	From bottom of set to bottom edge of screen (A2)
100	2.54	1.25	2.21	0.87	0.71	0.17	0.66	0.86
120	3.05	1.49	2.66	1.04	0.88	0.34	0.80	1.00
150	3.81	1.87	3.32	1.31	1.14	0.60	1.02	1.22
200	5.08	2.49	4.43	1.74	1.57	1.03	1.38	1.58
250	6.35	3.11	5.54	2.17	2.01	1.47	1.75	1.95
300	7.62	3.74	6.64	2.61	2.44	1.90	2.11	2.31
350	8.89	4.36	7.75	3.04	2.87	2.33	2.48	2.68

Unit : feet

Ultra-short focal length lens ET-DLE030  
Close-up system dimensions

Throw ratio				0.40:1				
Diagonal image size (Inches)	Diagonal image size (m)	Height (SH)	Width (SW)	Projection distance (From mirror reflective surface to screen) (L1)	From front of set to screen (L3)	From rear of set to screen (L4)	From top of set to bottom edge of screen (A1)	From bottom of set to bottom edge of screen (A2)
100	2.54	4.1	7.3	2.9	2.3	0.5	2.2	2.8
120	3.05	4.9	8.7	3.4	2.9	1.1	2.6	3.3
150	3.81	6.1	10.9	4.3	3.7	2.0	3.3	4.0
200	5.08	8.2	14.5	5.7	5.2	3.4	4.5	5.2
250	6.35	10.2	18.2	7.1	6.6	4.8	5.7	6.4
300	7.62	12.3	21.8	8.5	8.0	6.2	6.9	7.6
350	8.89	14.3	25.4	10.0	9.4	7.7	8.1	8.8

- \* The value for L1 may contain an error of within ±5%.
- \* When using vertical keystone correction, the images will be corrected so that they will tend to be smaller than the specified screen size.
- \* This measurement is not the distance between the rear of the projector and the wall, but is instead the distance between the rear of the projector and the screen surface. Leave at least 500 mm of space between the rear of the projector and the wall and any other objects in order to provide adequate ventilation space. If setting up the projector in a closed room, be sure to provide separate air conditioning and ventilation equipment. If there is insufficient ventilation in the room, radiated heat may build up and cause the protection circuit of the projector to operate.

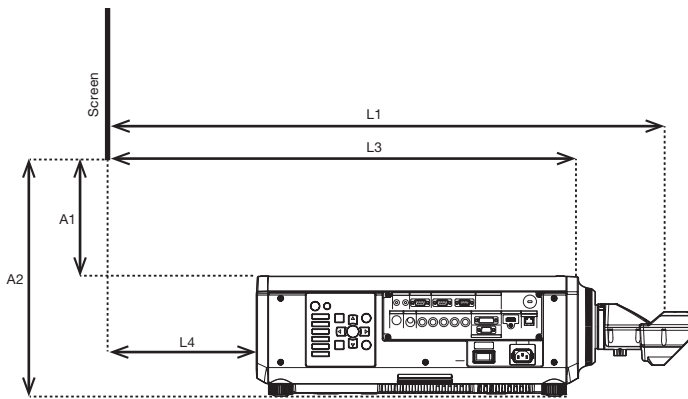

- L1: Projection distance (from screen to mirror reflective surface)
- L3: From screen to front of set
- L4: From screen to rear of set
- A1: From bottom edge of screen to top of set
- A2: From bottom edge of screen to bottom of set

Projection Distance Calculation Table

Screen aspect ratio 16:9

Projection distance calculation formula

$$L1 (m) = 0.3294 \times \text{Diagonal image size} + 0.0047$$

Calculation formula for distance from top of set to bottom edge of screen

$$A1 (m) = 0.2304 \times \text{Diagonal image size} - 0.07210$$

**Calculation of the projection distance**

For a screen size different from the above, use the equation below to calculate the projection distance.

**Aspect ratio 4:3**

ET-DLE085	minimum	$L (m) = (\text{diagonal screen size in inches}) \times 0.0170 - 0.0471$
	maximum	$L (m) = (\text{diagonal screen size in inches}) \times 0.0211 - 0.0442$
ET-DLE105	minimum	$L (m) = (\text{diagonal screen size in inches}) \times 0.0212 - 0.0511$
	maximum	$L (m) = (\text{diagonal screen size in inches}) \times 0.0284 - 0.0472$
ET-DLE150	minimum	$L (m) = (\text{diagonal screen size in inches}) \times 0.0280 - 0.0540$
	maximum	$L (m) = (\text{diagonal screen size in inches}) \times 0.0403 - 0.0498$
<i>Supplied lens/ ET-DLE170</i>	<i>minimum</i>	<i><math>L (m) = (\text{diagonal screen size in inches}) \times 0.0370 - 0.0746</math></i>
	<i>maximum</i>	<i><math>L (m) = (\text{diagonal screen size in inches}) \times 0.0517 - 0.0725</math></i>
ET-DLE250	minimum	$L (m) = (\text{diagonal screen size in inches}) \times 0.0488 - 0.0800$
	maximum	$L (m) = (\text{diagonal screen size in inches}) \times 0.0771 - 0.0792$
ET-DLE350	minimum	$L (m) = (\text{diagonal screen size in inches}) \times 0.0770 - 0.1351$
	maximum	$L (m) = (\text{diagonal screen size in inches}) \times 0.1163 - 0.1346$
ET-DLE450	minimum	$L (m) = (\text{diagonal screen size in inches}) \times 0.1165 - 0.3017$
	maximum	$L (m) = (\text{diagonal screen size in inches}) \times 0.1842 - 0.2991$
ET-DLE030	(fixed focus)	$L1 (m) = (\text{diagonal screen size in inches}) \times 0.0080 - 0.0047$ $L3 (m) = L1 - 0.166$ $L4 (m) = L1 - 0.704$
ET-DLE055	(fixed focus)	$L (m) = (\text{diagonal screen size in inches}) \times 0.0171 - 0.0476$

**Aspect ratio 16:9**

ET-DLE085	minimum	$L (m) = (\text{diagonal screen size in inches}) \times 0.0186 - 0.0471$
	maximum	$L (m) = (\text{diagonal screen size in inches}) \times 0.0230 - 0.0442$
ET-DLE105	minimum	$L (m) = (\text{diagonal screen size in inches}) \times 0.0231 - 0.0511$
	maximum	$L (m) = (\text{diagonal screen size in inches}) \times 0.0310 - 0.0472$
ET-DLE150	minimum	$L (m) = (\text{diagonal screen size in inches}) \times 0.0305 - 0.0540$
	maximum	$L (m) = (\text{diagonal screen size in inches}) \times 0.0439 - 0.0498$
<i>Supplied lens/ ET-DLE170</i>	<i>minimum</i>	<i><math>L (m) = (\text{diagonal screen size in inches}) \times 0.0403 - 0.0746</math></i>
	<i>maximum</i>	<i><math>L (m) = (\text{diagonal screen size in inches}) \times 0.0563 - 0.0725</math></i>
ET-DLE250	minimum	$L (m) = (\text{diagonal screen size in inches}) \times 0.0532 - 0.0800$
	maximum	$L (m) = (\text{diagonal screen size in inches}) \times 0.0840 - 0.0792$
ET-DLE350	minimum	$L (m) = (\text{diagonal screen size in inches}) \times 0.0839 - 0.1351$
	maximum	$L (m) = (\text{diagonal screen size in inches}) \times 0.1267 - 0.1346$
ET-DLE450	minimum	$L (m) = (\text{diagonal screen size in inches}) \times 0.1270 - 0.3017$
	maximum	$L (m) = (\text{diagonal screen size in inches}) \times 0.2007 - 0.2991$
ET-DLE030	(fixed focus)	$L1 (m) = (\text{diagonal screen size in inches}) \times 0.0087 - 0.0047$ $L3 (m) = L1 - 0.166$ $L4 (m) = L1 - 0.704$
ET-DLE055	(fixed focus)	$L (m) = (\text{diagonal screen size in inches}) \times 0.0186 - 0.0476$

- Distances calculated with the above equations will include a slight error.

**Formula for calculating possible heights when using the ET-DLE030**

If using a screen size which has not been previously mentioned, use the following calculation formulas to obtain the possible setting-up height.

For screen aspect ratio of 4:3      Possible setting-up height A1 (mm) = Projection screen size (inches) x 4.8-71.5  
 Possible setting-up height A2 (mm) = A1 + 200

For screen aspect ratio of 16:9      Possible setting-up height A1 (mm) = Projection screen size (inches) x 7.3-71.5  
 Possible setting-up height A2 (mm) = A1 + 200

\* There may be a small margin of error in the values obtained from the above formulas.

**Shift range**

Optical axis shift function allows to shift the position of a projected image as shown below.

**• Floor mount**

(When the lens except the ET-DLE085 and ET-DLE105 is mounted.)

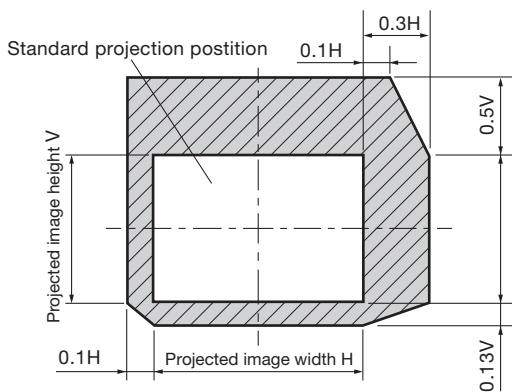

**• Ceiling mount**

(When the lens except the ET-DLE085 and ET-DLE105 is mounted.)

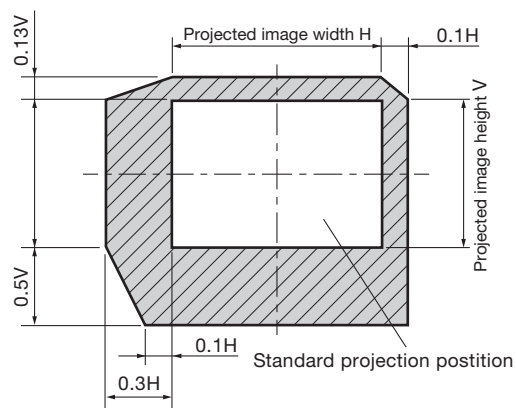

**• Floor mount**

(When the ET-DLE085 and ET-DLE105 is mounted.)

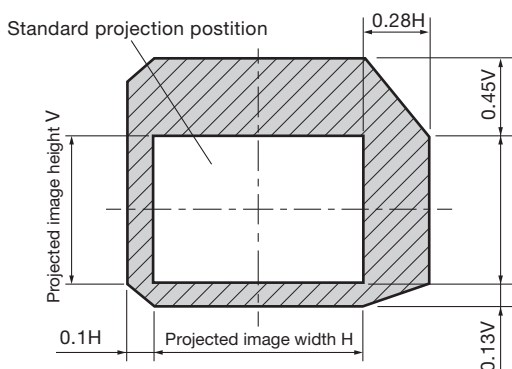

**• Ceiling mount**

(When the ET-DLE085 and ET-DLE105 is mounted.)

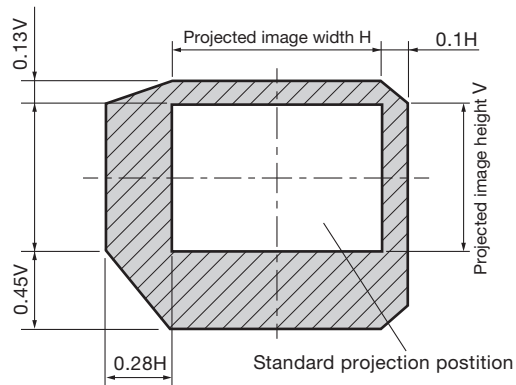

• The ET-DLE055 has a fixed short-focus lens. Therefore, the lens shift function provided in the main unit cannot be used.

**Installable angle**

Install the projector at an angle within the range shown below.

**FULL 360-degree projection**

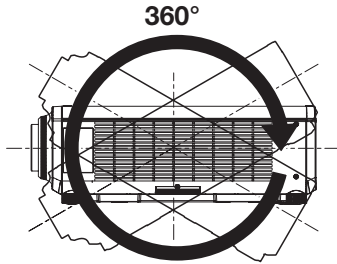

**Vertical 360-deg.**

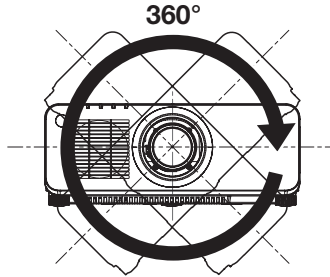

**Horizontal 360-deg.**

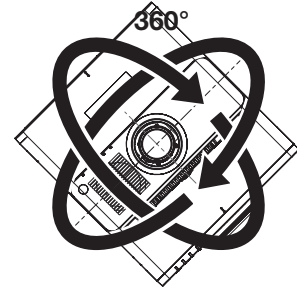

**Tilting 360-deg.  
(V&H combination)**

**List of compatible signals**

The following table specifies the video signals compatible with the projector.

- Symbols that indicate formats are as follows.
  - V : VIDEO, Y/C
  - R: RGB (analog)
  - Y: YCbCr/YPbPr (analog)
  - D: DVI-D
  - H: HDMI
- Input corresponding to each item in the plug and play column is as follows.
  - RGB2: RGB2 input
  - DVI-D: DVI-D input
  - HDMI/DL: HDMI input, DIGITAL LINK input

Compatible signal	Resolution (Dots)	Scanning freq.		Dot clock freq. (MHz)	Format	RGB2	Plug and Play**			HDMI DL
		H (KHz)	V (Hz)				EDID1	DVD-D EDID2	EDID3	
NTSC/NTSC4.43/PAL-M/PAL60	720 x 480i	15.7	59.9	—	V	—	—	—	—	—
PAL/PAL-N/SECAM	720 x 576i	15.6	50.0	—	V	—	—	—	—	—
480/60i	720 x 480i	15.7	59.9	13.5	R/Y	—	—	—	—	—
576/50i	720 x 576i	15.6	50.0	13.5	R/Y	—	—	—	—	—
480/60i	720(1440) x 480i*2	15.7	59.9	27.0	D/H	—	—	—	—	—
576/50i	720(1440) x 576i*2	15.6	50.0	27.0	D/H	—	—	—	—	—
480/60p	720 x 480	31.5	59.9	27.0	R/Y/D/H	—	✓	—	✓	✓
576/50p	720 x 576	31.3	50.0	27.0	R/Y/D/H	—	✓	—	✓	✓
720/60p	1280 x 720	45.0	60.0	74.3	R/Y/D/H	—	✓	—	✓	✓
720/50p	1280 x 720	37.5	50.0	74.3	R/Y/D/H	—	✓	—	✓	✓
1080/60i	1920 x 1080i	33.8	60.0	74.3	R/Y/D/H	—	✓	—	✓	✓
1080/50i	1920 x 1080i	28.1	50.0	74.3	R/Y/D/H	—	✓	—	✓	✓
1080/24p	1920 x 1080	27.0	24.0	74.3	R/Y/D/H	—	✓	—	✓	✓
1080/24sF	1920 x 1080i	27.0	48.0	74.3	R/Y/D/H	—	—	—	—	—
1080/25p	1920 x 1080	28.1	25.0	74.3	R/Y/D/H	—	✓	—	✓	—
1080/30p	1920 x 1080	33.8	30.0	74.3	R/Y/D/H	—	—	—	—	—
1080/60p	1920 x 1080	67.5	60.0	148.5	R/Y/D/H	—	✓	—	✓	✓
1080/50p	1920 x 1080	56.3	50.0	148.5	R/Y/D/H	—	✓	—	✓	✓
640 x 400/70	640 x 400	31.5	70.1	25.2	R/D/H	—	—	—	—	—
640 x 400/85	640 x 400	37.9	85.1	31.5	R/D/H	—	—	—	—	—
640 x 480/60	640 x 480	31.5	59.9	25.2	R/D/H	✓	✓	✓	✓	✓
640 x 480/67	640 x 480	35.0	66.7	30.2	R/D/H	—	—	—	—	—
640 x 480/73	640 x 480	37.9	72.8	31.5	R/D/H	✓	—	✓	✓	✓
640 x 480/75	640 x 480	37.5	75.0	31.5	R/D/H	✓	—	✓	✓	✓
640 x 480/85	640 x 480	43.3	85.0	36.0	R/D/H	—	—	—	—	—
800 x 600/56	800 x 600	35.2	56.3	36.0	R/D/H	✓	—	✓	✓	✓
800 x 600/60	800 x 600	37.9	60.3	40.0	R/D/H	✓	—	✓	✓	✓
800 x 600/72	800 x 600	48.1	72.2	50.0	R/D/H	✓	—	✓	✓	✓
800 x 600/75	800 x 600	46.9	75.0	49.5	R/D/H	✓	—	✓	✓	✓
800 x 600/85	800 x 600	53.7	85.1	56.3	R/D/H	—	—	—	—	—
832 x 624/75	832 x 624	49.7	74.6	57.3	R/D/H	✓	—	✓	✓	✓
1024 x 768/50	1024 x 768	39.6	50.0	51.9	R/D/H	—	—	—	—	—
1024 x 768/60	1024 x 768	48.4	60.0	65.0	R/D/H	✓	—	✓	✓	✓
1024 x 768/70	1024 x 768	56.5	70.1	75.0	R/D/H	✓	—	✓	✓	✓
1024 x 768/75	1024 x 768	60.0	75.0	78.8	R/D/H	✓	—	✓	✓	✓
1024 x 768/82	1024 x 768	65.5	81.6	86.0	R/D/H	—	—	—	—	—
1024 x 768/85	1024 x 768	68.7	85.0	94.5	R/D/H	—	—	—	—	—
1024 x 768/100	1024 x 768	81.4	100.0	113.3	R/D/H	—	—	—	—	—
1024 x 768/120	1024 x 768	98.7	120.0	139.1	R/D/H	✓	—	✓	✓	✓
1152 x 864/60	1152 x 864	53.7	60.0	81.6	R/D/H	—	—	—	—	—
1152 x 864/70	1152 x 864	64.0	70.0	94.2	R/D/H	—	—	—	—	—
1152 x 864/75	1152 x 864	67.5	75.0	108.0	R/D/H	—	—	—	—	—
1152 x 864/85	1152 x 864	77.1	85.0	119.7	R/D/H	—	—	—	—	—
1152 x 870/75	1152 x 870	68.7	75.1	100.0	R/D/H	✓	—	✓	✓	✓
1280 x 720/50	1280 x 720	37.1	49.8	60.5	R/D/H	—	—	—	—	—
1280 x 720/60	1280 x 720	44.8	59.9	74.5	R/D/H	—	—	—	—	—
1280 x 720/100	1280 x 720	76.3	100.0	131.8	R/D/H	—	—	—	—	—
1280 x 720/120	1280 x 720	92.6	120.0	161.6	R/D/H	—	—	—	—	—



The following table specifies the video signals compatible with the projector.

- Symbols that indicate formats are as follows.
  - V : VIDEO, Y/C
  - R: RGB (analog)
  - Y: YCbCr/YPbPr (analog)
  - D: DVI-D
  - H: HDMI
- Input corresponding to each item in the plug and play column is as follows.
  - RGB2: RGB2 input
  - DVI-D: DVI-D input
  - HDMI/DL: HDMI input, DIGITAL LINK input

Compatible signal	Resolution (Dots)	Scanning freq.		Dot clock freq. (MHz)	Format	Plug and Play*1				
		H (KHz)	V (Hz)			RGB2	EDID1	DVD-D EDID2	EDID3	HDMI DL
1280 x 768/50	1280 x 768	39.6	49.9	65.3	R/D/H	—	—	—	—	—
	1280 x 768	47.8	59.9	79.5	R/D/H	—	—	—	—	—
1280 x 768/60	1280 x 768	47.4	60.0	68.3	R/D/H	—	—	—	—	—
	1280 x 768*3	47.4	60.0	68.3	R/D/H	—	—	—	—	—
1280 x 768/75	1280 x 768	60.3	74.9	102.3	R/D/H	—	—	—	—	—
1280 x 768/85	1280 x 768	68.6	84.8	117.5	R/D/H	—	—	—	—	—
1280 x 800/50	1280 x 800	41.3	50.0	68.0	R/D/H	—	—	—	—	—
	1280 x 800	49.7	59.8	83.5	R/D/H	—	—	—	—	—
1280 x 800/60	1280 x 800	49.3	59.9	71.0	R/D/H	—	—	—	—	—
	1280 x 800*3	49.3	59.9	71.0	R/D/H	—	—	—	—	—
1280 x 800/75	1280 x 800	62.8	74.9	106.5	R/D/H	—	—	—	—	—
1280 x 800/85	1280 x 800	71.6	84.9	122.5	R/D/H	—	—	—	—	—
1280 x 960/60	1280 x 960	60.0	60.0	108.0	R/D/H	—	—	—	—	—
1280 x 1024/50	1280 x 1024	52.4	50.0	88.0	R/D/H	—	—	—	—	—
1280 x 1024/60	1280 x 1024	64.0	60.0	108.0	R/D/H	—	—	—	—	—
1280 x 1024/66	1280 x 1024	72.3	66.3	125.0	R/D/H	—	—	—	—	—
1280 x 1024/72	1280 x 1024	78.2	72.0	135.1	R/D/H	—	—	—	—	—
1280 x 1024/75	1280 x 1024	80.0	75.0	135.0	R/D/H	✓	—	✓	✓	✓
1280 x 1024/85	1280 x 1024	91.1	85.0	157.5	R/D/H	—	—	—	—	—
1366 x 768/50	1366 x 768	39.6	49.9	69.0	R/D/H	—	—	—	—	—
1366 x 768/60	1366 x 768	47.7	59.8	85.5	R/D/H	—	—	—	—	—
1400 x 1050/50	1400 x 1050	54.1	50.0	99.9	R/D/H	—	—	—	—	—
	1400 x 1050	64.0	60.0	108.0	R/D/H	—	—	—	—	—
1400 x 1050/60	1400 x 1050	65.3	60.0	121.8	R/D/H	—	—	—	—	—
	1400 x 1050	65.2	60.0	122.6	R/D/H	✓	—	✓	✓	✓
1400 x 1050/72	1400 x 1050	78.8	72.0	149.3	R/D/H	—	—	—	—	—
1400 x 1050/75	1400 x 1050	82.2	75.0	155.9	R/D/H	—	—	—	—	—
1440 x 900/50	1440 x 900	46.3	49.9	86.8	R/D/H	—	—	—	—	—
1440 x 900/60	1440 x 900	55.9	59.9	106.5	R/D/H	—	—	—	—	—
1600 x 900/50	1600 x 900	46.4	49.9	96.5	R/D/H	—	—	—	—	—
1600 x 900/60	1600 x 900	55.9	60.0	119.0	R/D/H	✓	—	✓	✓	✓
1600 x 1200/50	1600 x 1200	61.8	49.9	131.5	R/D/H	—	—	—	—	—
1600 x 1200/60	1600 x 1200	75.0	60.0	162.0	R/D/H	✓	—	✓	✓	✓
1680 x 1050/50	1680 x 1050	54.1	50.0	119.5	R/D/H	—	—	—	—	—
1680 x 1050/60	1680 x 1050	65.3	60.0	146.3	R/D/H	—	—	—	—	—
1920 x 1080/50	1920 x 1080	55.6	49.9	141.5	R/D/H	—	—	—	—	—
	1920 x 1080	66.6	59.9	138.5	R/D/H	—	—	—	—	—
1920 x 1080/60	1920 x 1080*3	66.6	59.9	138.5	R/D/H	—	—	—	—	—
	1920 x 1080*4	67.2	60.0	173.0	R	—	—	—	—	—
1920 x 1200/50	1920 x 1200	61.8	49.9	158.3	R/D/H	—	—	—	—	—
1920 x 1200/60	1920 x 1200*4	74.6	59.9	193.3	R	—	—	—	—	—
1920 x 1200/60RB	1920 x 1200*3	74.0	60.0	154.0	R/D/H	✓	—	✓	—	—

\*1 Signals with a ✓ in the Plug and play columns are signals described in EDID (extended display identification data) of the projector. If a signal has no ✓ in the Plug and play columns but has an entry in the Format column, it can be input. For signals without a ✓ in the Plug and play columns, there are instances when resolution cannot be selected on the computer even though the projector supports them.

\*2 Only compatible with dot clock frequency of 27 MHz (pixel repetition signal)

\*3 Compliant with VESA CVT-RB (Coordinated Video Timing-Reduced Blanking).

\*4 Image resolution is reduced by the image processing circuit before projection.

NOTE:

- A signal with a different resolution is converted to the number of display dots. The number of display dots is as follows.
  - 1920 x 1200
- The "i" at the end of the resolution indicates an interlaced signal.
- When interlaced signals are connected, flickering may occur on the projected image.
- DIGITAL LINK input compatible signal is the same as HDMI input compatible signal.

**Notes on projector placement and operation**

- Prevent hot and cool air from the air conditioning system to blow directly to the ventilation ports (intake and exhaust) of the projector.
- Do not stack projectors on top of each other.
- Do not block the ventilation ports (intake and exhaust) of the projector.

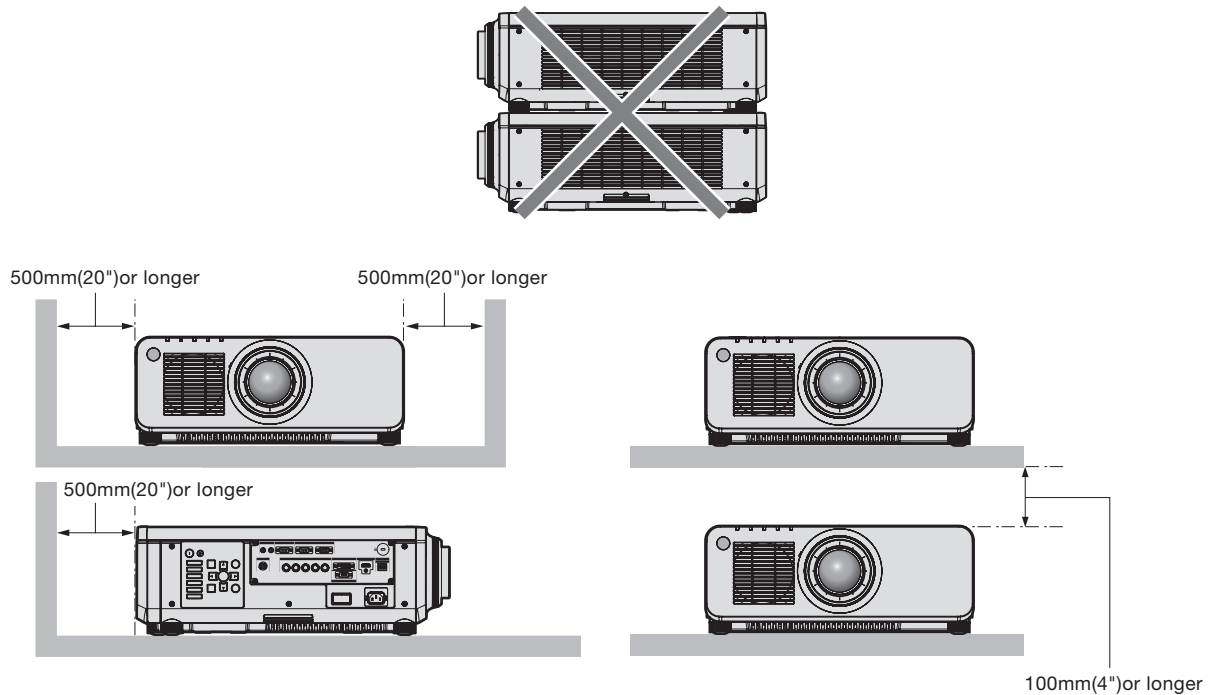

- Do not install the projector in a confined space.  
When installing the projector in a confined space, provide air conditioning or ventilation separately.  
Exhaust heat may accumulate when the ventilation is not enough, triggering the protection circuit of the projector.